

GPS Receiver for Space Use

Applications

- CubeSat nanosatellite GPS
- SUPERNOVA™ nanosatellite GPS

Features

- For use with 104-pin CubeSat Kit™ Bus
- Compatible with entire NovAtel® OEM719 multi-frequency, multi-constellation GNSS receiver module family;
- Compatible with a wide range of active GPS antennas
- Supplied with vibration-resistant OEM719 receiver with COCOM limits unblocked
- With dedicated nanopower supervisor MCU for:
 - GPS power control
 - GPS power monitor
 - GPS reset and external events
 - GPS isolation from CSK bus signals
 - I2C interface / "back door"
 - Additional user-defined functionality
 - CLK Out clock w/divider
- GPS receiver communication ports:
 - TXD1/RXD1 ↔ CSK Bus
 - TXD2/RXD2 ↔ supervisor MCU
 - USB ↔ host via micro-AB connector
- GPS receiver outputs:
 - 50Ω PPS signal (x2)
 - Variable frequency signal (VARF)
 - Position Valid (PV) indicator
- Enhanced EMC / EMI design yields improved SNR over unshielded receiver
- 3 LEDs for lock, status and SupMCU status
- On-board Vinti & SGP4 orbit propagators
- Integrated heatsink / EM shield is tied to thermal conductive pads for use with CSK thermal standoffs in all four corners (top and bottom)
- Flexible interface to CSK –RESET signal
- Auto-selected power sources:
 - +5V & +3.3V from CSK Bus
 - +5V from USB
- Independent latchup (device overcurrent) protection on critical subsystems



ORDERING INFORMATION

Pumpkin P/N 710-00908

Option Code	GPS band(s) & CubeSat Kit Bus Connector ¹
c/00	Non-stackthrough
c/10 (standard)	Stackthrough
f/0 (standard)	L1 GPS
f/1	L1/L2 GPS

Contact factory for availability of optional configurations.
Option code /10 shown.



CAUTION

Electrostatic
Sensitive
Devices

Handle with
Care



- PC/104-size footprint
- Stackable 104-pin CubeSat Kit Bus connectors includes processor's complete I/O space, user-assignable signals and more
- Wiring-free module interconnect scheme
- 6-layer gold-plated blue-soldermask PCB with triple ground planes for enhanced signal integrity
- Supervisor MCU programmed with Pumpkin's space-proven Salvo™ RTOS for easy user customization

¹ Stackthrough connectors are used in CubeSat Kit configurations where the MB is not in Slot 0.

CHANGELOG

Rev.	Date	Author	Comments
A	20180524	AEK	Initial release of hardware Rev D.

AS-DELIVERED CONFIGURATION

The GPSRM 1 GPS receiver module is normally supplied as part of Pumpkin P/N 711-01012, with:

711-00908 Pumpkin GPSRM 1 GPS receiver module
 711-01013 Pumpkin USB Debug Adapter Kit
 709-01022 Pumpkin GPSRM 1 firmware (object format)²
 634-01014 USB 2.0 male to micro B 5-pin male cable

CONNECTOR OPTIONS

Code	Description / Application	H1 & H2 52-pin Connectors
c/00	For use at the bottom of a module stack	Non-stackthrough
c/10	For use anywhere in a module stack	Stackthrough

GPS RECEIVER OPTIONS

Code	Description / Application	OEM719 P/N	Firmware P/N
f/00	Single-frequency (L1)	OEM719-G1S-B0G-TT0-H	
f/01	Dual-frequency (L1/L2)	OEM719-D1S-B0G-TT0-H	

Contact the factory for more constellation and frequency options. The GPSRM 1 can be updated in the field with appropriate software upgrades from NovAtel.

OPERATIONAL DESCRIPTION

The GPSRM 1 GPS receiver adds GPS functionality to the CubeSat Kit™ (CSK) by integrating a NovAtel® OEM719-series receiver onto a CSK-compatible module. A supervisor MCU controls power and interface to the CSK bus. The interface to the supervisor MCU is via I2C.

The GPSRM 1 is designed to mount directly above the combination of a CSK Motherboard (MB) + Pluggable Processor Module (PPM), at the standard inter-module distance of 0.600" (15.24mm), using a GPS antenna cable terminated in a right-angle MCX plug. This arrangement provides the necessary clearance for the GPS antenna cable's connector. It can also be placed in other slots in a compatible nanosatellite architecture.

In its default configuration, the GPSRM 1 utilizes the NovAtel® OEM719-G1S-B0G-TT0-H³ GPS L1 receiver module with a 20Hz update rate. As fitted on the GPSRM 1, these GPS receiver modules have had their COCOM limits removed / unblocked.

For an additional cost, customers can request any model from the OEM719 family for use on the GPSRM 1. This includes versions with L1/L2/L2C GPS and/or multi-constellation GPS/GLONASS/Beidou/Galileo signal tracking for enhanced frequency stability. Please contact the factory for details and pricing.

Power to the GPS receiver is under the control of the PIC24E-series supervisor MCU and can be switched on or off via I2C commands. Power is automatically selected from available power: either (external) USB or the CubeSat Kit bus.

The GPS receiver's **-RESET**, **EVENT1** and **EVENT2** inputs are under the control of the supervisor MCU.⁴

The first serial port of the GPS receiver is normally used to communicate with the rest of the CubeSat via one of the three CubeSat Kit bus signal pairs **IO.4 & IO.5**, **IO.16 & IO.17** or **IO.32 & IO.33**. This serial port can be isolated from the CubeSat Kit bus via I2C commands. The second serial port of the GPS receiver is connected to the supervisor MCU and can be used to transfer data and commands between the GPS receiver and the supervisor MCU. The third serial port of the GPS receiver –

² Provided separately via the Pumpkin user download area, when updates are available.

³ Throughout this datasheet, the NovAtel GPS receiver will be referred to as the "OEM719."

⁴ The OEM719 receiver's **CAN2TX** and **CAN2RX** signals are left unconnected.

implemented as USB – is connected directly to a micro-AB USB connector. This USB connection can also power the GPS receiver.

A Position Valid (PV) LED indicator from the GPS receiver is provided, as well as a status LED from the supervisor MCU. Additionally, the GPS receiver's own red/green LED is visible through the integrated EMC / EMI shield and heatsink.

The 50Ω **TIME**MARK (PPS) signal from the GPS receiver is available in one of two user-selectable forms: on an MCX jack for use with discrete RF cabling, and on the CubeSat Kit bus PPS signal.

The **VARF** (variable frequency) signal from the GPS receiver is present on an MMCX jack for use with discrete RF cabling, and also (optionally) on IO.31 of the CubeSat Kit bus.

An additional TX/RX debug port to the supervisor MCU is provided, to aid in supervisor MCU firmware development & debugging. Additionally, a 20-pin connector is provided as a means of connecting expansion boards (where possible) under the control of the supervisor MCU. Lastly, an MMCX connector is provided for measuring the supervisor MCU's unbuffered internal clock frequency.

An accurate orbit propagator is provided and is accessed through the command and telemetry interface of the SupMCU. The orbit propagator operates independently of the status of the GPS receiver.

Particular attention has been paid to the shielding and heatsinking of the OEM719 module. An integrated EMC / EMI shield and heatsink covers the entire OEM719 module and is electrically and thermally tied to all four corner standoff locations. Special attention in the PCB design has been paid to avoid any isolated dielectric regions resulting from unconnected swatches of copper.

A related module – the AIM 2 – provides the same features and performance in a form factor designed expressly for Pumpkin's MISC 3 and SUPERNOVA buses. AIM 2 is for Pumpkin internal use only and is not offered for sale individually.

ABSOLUTE MAXIMUM RATINGS

Parameter	Symbol	Value	Units
Operating temperature	T_A	-40 to +85	°C
Voltage on +5V_USB bus		-0.3 to +6	V
Voltage on +5V_SXS bus			
Voltage on VCC_SXS bus			
Voltage on local VCC_MCU bus		-0.3 to +5.5	V

PHYSICAL CHARACTERISTICS

Parameter	Conditions / Notes	Symbol	Min	Typ	Max	Units
Mass ⁵	With aluminum heatsink / EM shield			109		g
Height of components above PCB	With mating cable to MCX PPS jack				11	mm
Height of components below PCB	Without GPS antenna cable connected				2.75	mm
	With GPS antenna cable connected via RA MCX plug				5.5	
PCB width	Corner hole pattern matches PC/104			96		mm
PCB length				90		mm
PCB thickness				1.6		mm
CubeSat Kit Bus Connector terminal pitch	Horizontal or vertical distance to nearest terminal			2.54		mm
Cross-sectional area of vent hole	Surrounds MCX antenna connector			0.15		cm ²
Volume of ventable air enclosed within EM shield	Includes air underneath/inside RF shields of OEM719 module ⁶				21	cm ³

⁵ With OEM719-G1S-B0G-TT0-H and with heatsink / EM shield fitted. Dual-band OEM719 versions may be slightly heavier.

⁶ This volume of air is inaccessible, since getting to it would require removal of the OEM719's RF shields and would thereby seriously compromise its performance.

SIMPLIFIED MECHANICAL LAYOUT ⁷

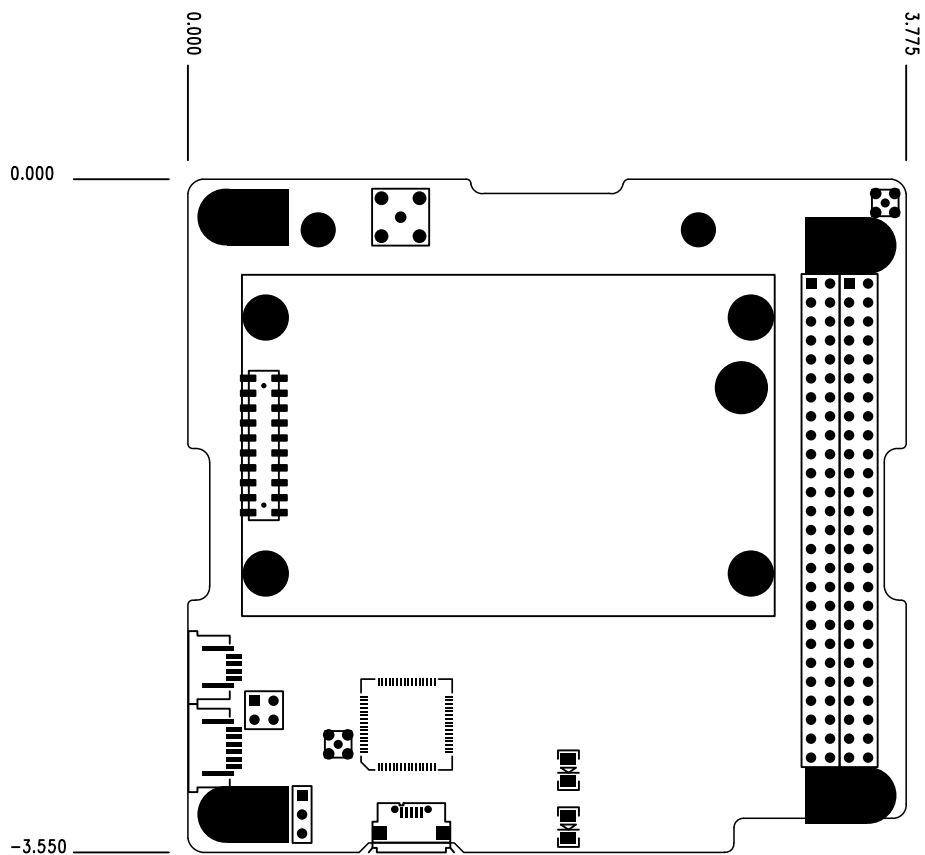

⁷ Dimensions in inches.

ELECTRICAL CHARACTERISTICS

(T = 25°C, +5V bus = +5V unless otherwise noted)

Parameter	Conditions / Notes	Symbol	Min	Typ	Max	Units
Operating power consumption	Supervisor MCU & GPS active, no antenna connected	$P_{OP_SUP_GPS_LNA}$		1.3		W
	Supervisor MCU active, GPS unpowered	P_{OP_SUP}		25		mW
Operating current ⁸	Supervisor MCU & GPS active, with active antenna connected	$I_{OP_SUP_GPS_LNA}$		300		mA
	Supervisor MCU & GPS active, no antenna connected	$I_{OP_SUP_GPS}$		260		mA
	Supervisor MCU active, GPS unpowered	I_{OP_SUP}		4.5		mA
	Supervisor MCU asleep, GPS unpowered	I_{SLEEP}		1.5		mA
Supervisor MCU internal clock frequency	Base frequency, can be multiplied by onboard PLL	f_{CLK_MCU}	7.3728			MHz
USB bus current ⁹	Powered over USB	I_{USB_MAX}			500	mA
Overcurrent trip point for OEM719	For +3.3V, set by R19 & R20	$I_{TRIP_3V3_GPS}$		TBD		mA
	For +5V, set by R15 & R16	$I_{TRIP_+5V_GPS}$		TBD		mA
Serial signal speed through any on-board isolator (ν_4 & ν_5)			50			MHz

OEM719 MODULE ELECTRICAL CHARACTERISTICS¹⁰

Parameter	Conditions / Notes	Min	Typ	Max	Units	
PPS Output at J7	Impedance		50		Ω	
	Rise & fall times		6		ns	
	Negative pulse width		1.000		ms	
	Amplitude (3V3_GPS = +3.3V, unterminated)			3.24		V
	Amplitude (3V3_GPS = +3.3V, terminated with 50 Ω)			2.40		
Effect on GPS SNR of GPSRM 1's EM shield	Observed SNR improvement of multiple, individual GPS satellites with GPSRM 1 EM shield present and absent, using NovAtel® receiver software.		5		dB	
Timing accuracy	Locked to GPS			20	ns	
Allan deviation	$\tau = 1\text{sec}$, VARF output and internal TCXO		10^{-10} to 10^{-11}			
TCXO frequency stability	Long-term aging ¹¹			10	ppm	

⁸ Terrestrial GPS receiver tracking a minimum of 5 satellites when active antenna with LNA is connected.

⁹ The OEM719's USB interface is configured at the factory as a bus- or self-powered device.

¹⁰ Timing performance per NovAtel communications with Pumpkin in January 2015. For a deeper understanding of the OEM719 family's timing references and performance, please contact NovAtel directly.

¹¹ Each OEM719 TCXO is pre-aged, and its aging effects are accounted for in the OEM719's design.

I2C CHARACTERISTICS

Parameter	Conditions / Notes	Min	Typ	Max	Units
I2C address	7-bit I2C address		0x51		
I2C clock speed				400	kHz
I2C pull-up resistors	No pull-up resistors are fitted to <code>SCL_SYS</code> or <code>SDA_SYS</code>		∞		Ω

USB DEVICE CHARACTERISTICS

Parameter	Conditions / Notes	Value
Speed	USB 2.0 compatible	Full Speed (12Mbps)
Vendor ID (VID)		0x09D7
Product ID (PID)		0x0100
Required driver	Supplied by NovAtel	

ORBIT PROPAGATOR CHARACTERISTICS

Parameter	Conditions / Notes	Min	Typ	Max	Units
Kepler algorithm convergence	Based on improved kelper2v.c code.		No known issues		
Vinti algorithm version	Based on improved vinti7.c code.		7		
Solution time	SupMCU running at default speed			1	s
Position error	Average magnitude, LEO orbits, 24-hour propagation time		6		km

BLOCK DIAGRAM

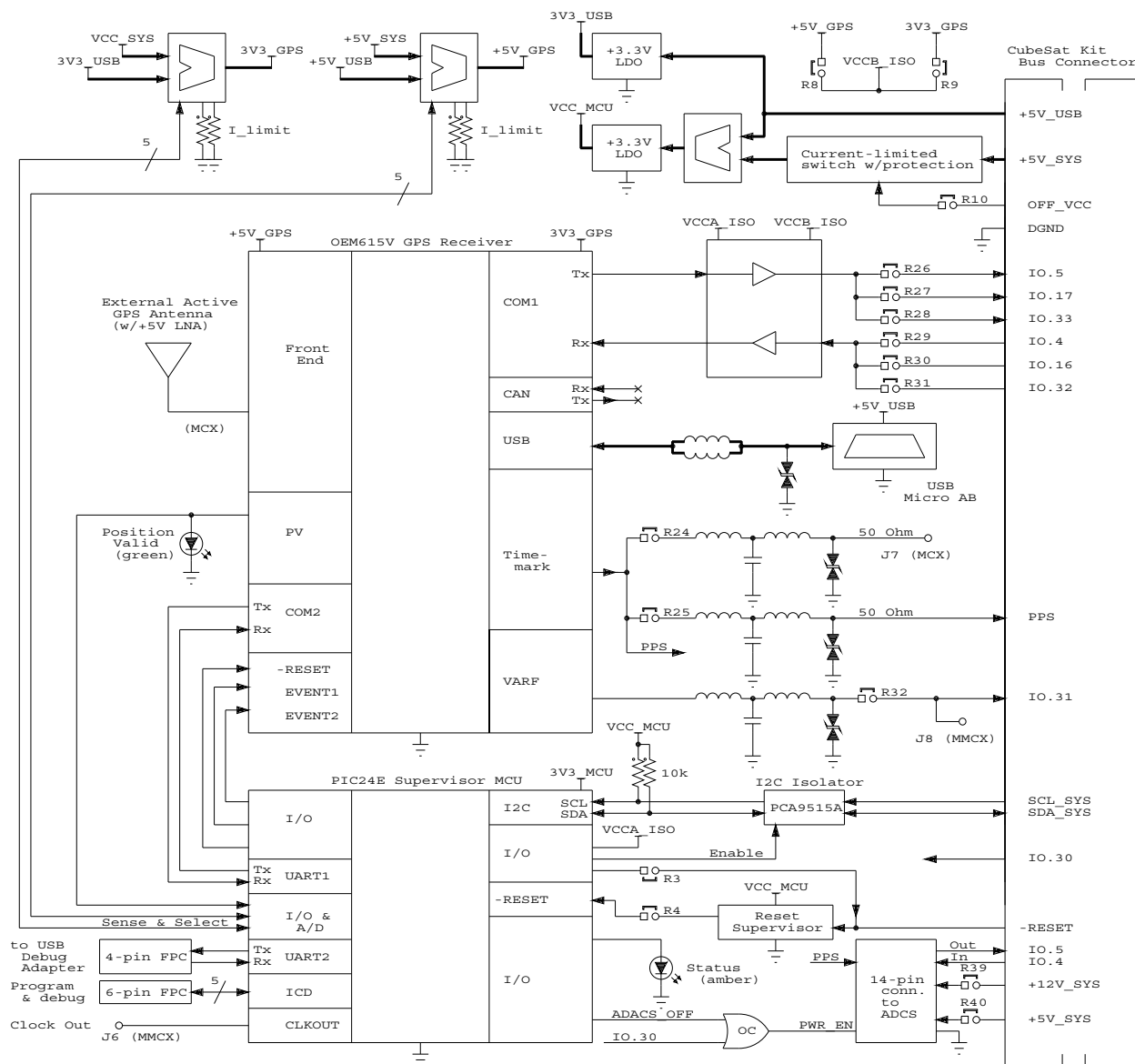

CubeSat Kit Bus PIN DESCRIPTIONS

CubeSat System Bus

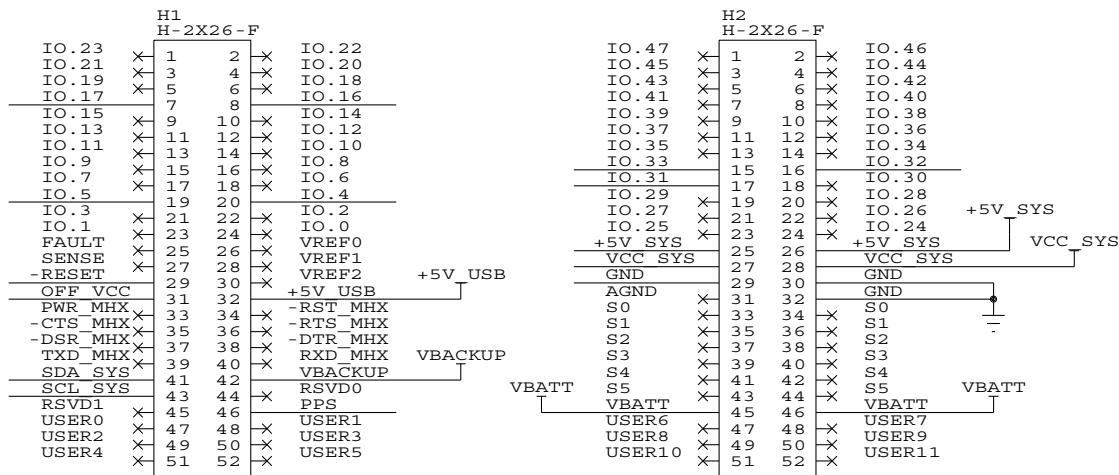

CubeSat Kit Bus PIN DESCRIPTIONS – I/O

Name	Pin	I/O	Description
IO.0	H1.24		Not connected.
IO.1	H1.23		Not connected.
IO.2	H1.22		Not connected.
IO.3	H1.21		Not connected.
IO.4	H1.20	I	Serial input to the GPS receiver's RX1D pin. This input receives data from IO.4 if/when jumper ¹² R29 is fitted. Typically serial data UTX0 from the PPM processor to the GPSRM 1.
IO.5	H1.19	O	Serial output from the GPS receiver's TX1D pin. This output sends data to IO.5 if/when jumper R26 is fitted. Typically serial data URX0 to the PPM processor to the GPSRM 1.
IO.6	H1.18		Not connected.
IO.7	H1.17		Not connected.
IO.8	H1.16		Not connected.
IO.9	H1.15		Not connected.
IO.10	H1.14		Not connected.
IO.11	H1.13		Not connected.
IO.12	H1.12		Not connected.
IO.13	H1.11		Not connected.
IO.14	H1.10		Not connected.
IO.15	H1.9		Not connected.
IO.16	H1.8	I	Serial input to the GPS receiver's RX1D pin. This input receives data from IO.16 if/when jumper R30 is fitted. Typically serial output from a module to the GPSRM 1.
IO.17	H1.7	O	Serial output from the GPS receiver's TX1D pin. This output sends data to IO.17 if/when jumper R27 is fitted. Typically serial input to a module from the GPSRM 1.
IO.18	H1.6		Not connected.
IO.19	H1.5		Not connected.
IO.20	H1.4		Not connected.
IO.21	H1.3		Not connected.
IO.22	H1.2		Not connected.
IO.23	H1.1		Not connected.

¹² On the GPSRM 1, all jumpers are implemented as zero-Ohm resistors soldered in place at time of assembly at the factory.

CubeSat Kit GPSRM 1 Rev. D

IO.24	H2.24		Not connected.
IO.25	H2.23		Not connected.
IO.26	H2.22		Not connected.
IO.27	H2.21		Not connected.
IO.28	H2.20		Not connected.
IO.29	H2.19		Not connected.
IO.30	H2.18	I	Input to
IO.31	H2.17	O	Variable-frequency output from the GPS receiver's VARF pin. This output places the VARF square wave on IO.31 if/when jumper R32 is fitted. Typically used by modules desiring a high-accuracy clock signal.
IO.32	H2.16	I	Serial input to the GPS receiver's RX1D pin. This input receives data from IO.32 if/when jumper R31 is fitted. Typically serial output from a module to the GPSRM 1.
IO.33	H2.15	O	Serial output from the GPS receiver's TX1D pin. This output sends data to IO.33 if/when jumper R28 is fitted. Typically serial input to a module from the GPSRM 1.
IO.34	H2.14		Not connected.
IO.35	H2.13		Not connected.
IO.36	H2.12		Not connected.
IO.37	H2.11		Not connected.
IO.38	H2.10		Not connected.
IO.39	H2.9		Not connected.
IO.40	H2.8		Not connected.
IO.41	H2.7		Not connected.
IO.42	H2.6		Not connected.
IO.43	H2.5		Not connected.
IO.44	H2.4		Not connected.
IO.45	H2.3		Not connected.
IO.46	H2.2		Not connected.
IO.47	H2.1		Not connected.

CubeSat Kit Bus PIN DESCRIPTIONS – Analog References

Name	Pin	I/O	Description
VREF0	H1.26		Not connected.
VREF1	H1.28		Not connected.
VREF2	H1.30		Not connected.

CubeSat Kit Bus PIN DESCRIPTIONS – Reserved

Name	Pin	I/O	Description
RSVD0	H1.44	–	Not connected.
RSVD1	H1.45	–	Not connected.

CubeSat Kit Bus PIN DESCRIPTIONS – I2C Bus

Name	Pin	I/O	Description
SDA_SYS	H1.41	I/O	I2C data. To/from supervisor MCU (an I2C slave device) via a PCA9515A I2C isolator. Typically from the PPM processor.
SCL_SYS	H1.43	I	I2C clock. To supervisor MCU (an I2C slave device) via a PCA9515A I2C isolator. Typically from the PPM processor.

CubeSat Kit Bus PIN DESCRIPTIONS – Control & Status

Name	Pin	I/O	Description
-FAULT	H1.25		Not connected.
SENSE	H1.27		Not connected.
-RESET	H1.29	I/O	Input to and/or output from reset supervisor controlling supervisor MCU. Functionality depends on resistors R3 & R4.
OFF_VCC	H1.31	I	When resistor R10 is fitted and no USB power is present, an active signal on this pin will disable VCC_MCU power to the supervisor MCU.
PPS ¹³	H1.46	O	PPS. From the GPS receiver's TIMEMARK (PPS) output. This output is present whenever the GPS receiver is powered and operating. 50Ω impedance.

CubeSat Kit Bus PIN DESCRIPTIONS – RBF and Separation Switches

Name	Pin	I/O	Description
S0	H2.33 H2.34		Not connected.
S1	H2.35 H2.36		Not connected.
S2	H2.37 H2.38		Not connected.
S3	H2.39 H2.40		Not connected.
S4	H2.41 H2.42		Not connected.
S5	H2.43 H2.44		Not connected.

CubeSat Kit Bus PIN DESCRIPTIONS – Power

Name	Pin	I/O	Description
VBATT	H2.45 H2.46	I	Battery voltage. EPS-dependent. Typically +7V to +10V. To expansion connector H3.5 & H3.6 only.
+5V_USB	H1.32	I/O	+5V USB power. From USB host.
+5V_SYS	H2.25 H2.26	I	+5V system power.
PWR_MHX	H1.33		Not connected.
VBACKUP	H1.42	I	Battery backup voltage. To expansion connector H3.8 only.
VCC_SYS	H2.27 H2.28	I	VCC System power. Assumed to be +3.3V.
AGND	H2.31		Not connected.
DGND	H2.29 H2.30 H2.32	-	Digital ground.

CubeSat Kit Bus PIN DESCRIPTIONS – Transceiver Interface

Name	Pin	I/O	Description
-RST_MHX	H1.34		Not connected.
-CTS_MHX	H1.35		Not connected.
-RTS_MHX	H1.36		Not connected.
-DSR_MHX	H1.37		Not connected.
-DTR_MHX	H1.38		Not connected.
TXD_MHX	H1.39		Not connected.
RXD_MHX	H1.40		Not connected.

¹³ This signal was formerly called RSRVD2 and was reserved.

CubeSat Kit Bus PIN DESCRIPTIONS – User-defined

Name	Pin	I/O	Description
USER0	H1.47		Not connected.
USER1	H1.48		Not connected.
USER2	H1.49		Not connected.
USER3	H1.50		Not connected.
USER4	H1.51		Not connected.
USER5	H1.52		Not connected.
USER6	H2.47		Not connected.
USER7	H2.48		Not connected.
USER8	H2.49		Not connected.
USER9	H2.50		Not connected.
USER10	H2.51		Not connected.
USER11	H2.52		Not connected.

IN-CIRCUIT DEBUGGING PIN DESCRIPTIONS

The Microchip® ICD®-compatible debugging/ programming connector J1 is implemented with a standard 6-pin Pumpkin PIC24 FPC connector. It is designed to mate to a Pumpkin JFPC-PIC24 debugging adapter via a 6-terminal flexible printed circuit (cable). This in turn can be connected to various Microchip in-circuit debuggers and programmers.

Name	Pin	I/O	Description
	J1.1	–	Unused.
PGEC	J1.2	I/O	PGEC1 – clock signal for in-circuit debugging.
PGED	J1.3	I/O	PGED1 – data signal for in-circuit debugging.
DGND	J1.4	–	Digital ground.
VCC	J1.5	–	Supervisor MCU power.
-MCLR	J1.6	I	Supervisor MCU's reset.

DEBUGGING ADAPTER PIN DESCRIPTIONS

The Pumpkin USB Debugging Adapter-compatible debugging connector J2 is implemented with a standard 4-pin Pumpkin USB Debug FPC connector. It is designed to mate to a Pumpkin USB Debugging Adapter via a 4-terminal flexible printed circuit (cable).

Name	Pin	I/O	Description
VCC	J2.1	–	Supervisor MCU power. When used with the GPSRM 1, users must ensure that this voltage from the Pumpkin USB Debug Adapter is set to 3.3V, or disconnected (preferred).
DGND	J2.2	–	Digital ground.
TXD	J2.3	O	Asynchronous serial data out of the Supervisor MCU.
RXD	J2.4	I	Asynchronous serial data into the Supervisor MCU.

OEM719 PPS Output

The GPS receiver has a 50Ω output driver for its **TIMEMARK** (PPS) signal. The default valid PPS signal is a low-going, 1.000ms pulse every second that is synchronized to GPS time when a valid position has been computed. Its behavior can be configured via commands directly to the GPS receiver.

The GPSRM 1 module provides two PPS outputs from the GPS receiver's **TIMEMARK** signal:

1. PPS is available at connector **J7** – an MCX jack – when jumper **R24** is fitted.
2. PPS is available on connector **H1.46** when jumper **R25** is fitted.¹⁴

By default, jumpers **R24** (for PPS to **J7**) and **R24** (for PPS to **H1.46**) are both fitted, thus making PPS available on both **J7** and **H1.46**. Customers can choose to remove one or the other based on their system-level design in an attempt to maximize the quality of the PPS signal at its endpoint(s).

For proper operation and accurate timing, the **TIMEMARK** (PPS) output requires a 50Ω termination. No termination is provided on the GPSRM 1 module. It is up to the end-user to provide the proper 50Ω termination if/when utilizing the GPSRM 1's PPS feature. Only one 50Ω termination should be applied to the PPS signal; either via **J6** or via **H1.46**.

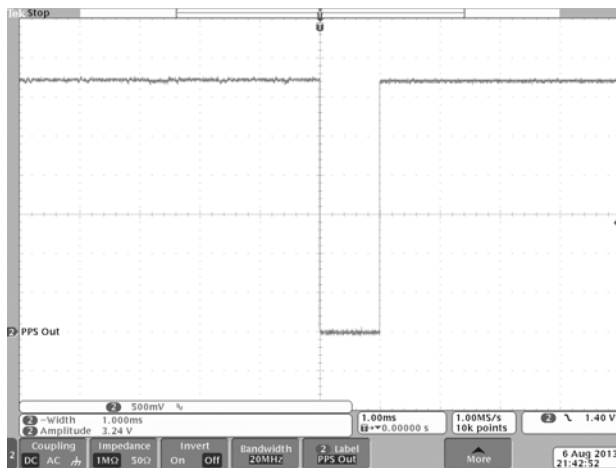

Figure 1: PPS on **J7**, unterminated. **R24** & **R25** fitted.

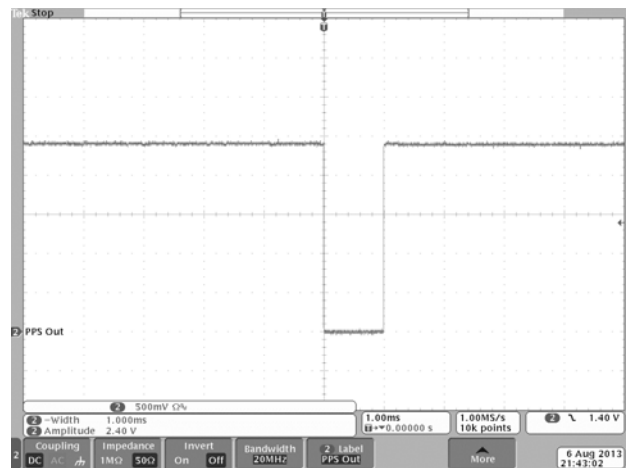

Figure 2: PPS on **J7**, terminated (50Ω) at oscilloscope. **R24** & **R25** fitted.

OEM719 VARF Output

The GPS receiver has a programmable variable-frequency output (**VARF**), that is coherent with its PPS output. Its enabled / disabled status, period and duty cycle can all be configured via commands directly to the GPS receiver. **VARF**'s period and duty cycle can be set with 10ns resolution.

VARF can replace a user's TCXO on another module, as long as the need for a stable and accurate frequency reference is compatible with the power requirements of the GPS receiver.

The GPSRM 1 provides the GPS receiver's **VARF** in two forms to the user:

1. On MMCX connector **J8**.
2. On the CubeSat Kit Bus Connector **IO.31**, if zero-Ohm jumper **R32** is fitted.

For example, the GPS receiver's `frequencyout enable 40 80` command results in a 1.25MHz output pulse train via **VARF**, as shown below.

¹⁴ The signals on the CubeSat Kit Bus Connector are not controlled-impedance signals. Therefore the customer will have to experiment with the ideal termination (e.g., on another module in the module stack) in their particular application in order to achieve the best possible waveform from the PPS signal.

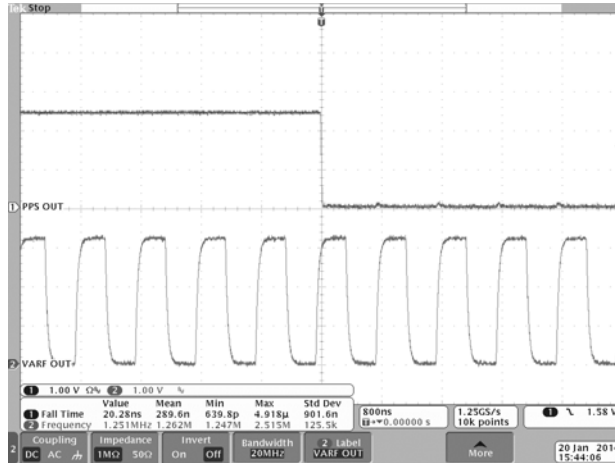

Figure 3: Resulting VARF output (below) on J8 for OEM719 frequencyout enable 40 80 command. Shown with TIMEMARK output (above) on J7 with OEM719 locked to GPS. R32 not fitted.

CLK Out Output

The GPSRM 1 provides an additional clock output – CLK out – albeit with much less accuracy than the GPS-locked GPS receiver's TIMEMARK and VARF. CLK out is the CPU clock of the GPSRM 1's Supervisor MCU, with a selectable postscaling divider of 1 to 2¹⁵ in sixteen steps. This clock is generated on the Supervisor MCU via an internal high-accuracy RC oscillator and is presented on one of the Supervisor MCU's output pins. The nominal value of this oscillator is 7.3728MHz at room temperature.

The GPSRM 1 provides the Supervisor MCU's CLK out in just one form to the user:

1. On MMCX connector J6.

CLK out is controlled via commands to the GPSRM 1's Supervisor MCU, and is off by default. Apart from some additional power consumption and possible noise associated with driving the CLK out output pin, there is no discernable effect on the Supervisor MCU when CLK out is active.

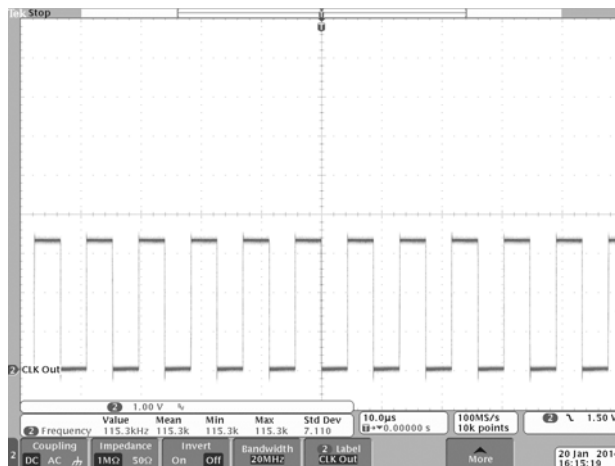

Figure 4: CLK out output on J6 when Supervisor MCU is commanded to output MCU clock with the divider set to 64.

OEM719 COM1 Output

When the GPSRM 1's passthrough feature is enabled, the GPS receiver's COM1 port is mapped to two pins on the CubeSat Kit Bus. A typical usage for the COM1 port is for the CubeSat Kit's PPM to command the OEM719 (e.g., to start logging), and for the OEM719 to respond with logs in human-readable form that will be received and parsed by the PPM. With passthrough enabled, the CubeSat Kit's PPM has the

entire command set of the OEM719 available to configure, command and receive telemetry from the OEM719.

An example of the serial output stream of the GPS receiver's COM1 port is shown below:

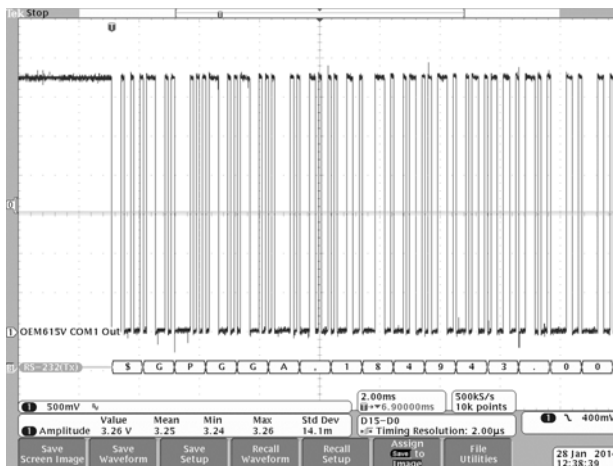

Figure 5: OEM719 COM1 output on CubeSat Kit Bus after OEM719 receives LOG COM1 GPGGA ONTIME 1 command.¹⁵

Vinti Orbit Propagator

The GPSRM 1's SupMCU is preprogrammed with the Vinti orbit propagator (OP) based on the Vinti7 codebase.¹⁶ The Vinti OP is exceptionally efficient in terms of speed, accuracy and robustness. It has been verified under millions of test cases and utilizes a new version of the 2-body orbit propagator kepler2v.c as part of its computations.

Inputs to the Vinti OP are double-precision GPS position and velocity (in km and km/s), and start and end times (in seconds) and are provided via the GPSRM 1's SCPI interface. The OP can propagate forwards or backwards. These inputs are compatible with the outputs of the OEM719 GPS receiver; hence the most recent GPS lock (ECEF) as acquired by the OEM719 inside the GPSRM 1 can be converted to ECI and used as inputs to the OP, with the reverse conversion (ECI to ECEF and ECEF to lat/long/alt) applied to the OP's outputs. Outputs from the Vinti OP are provided in double-precision form via the GPSRM 1's telemetry interface once the OP computations are complete.

The OP runs inside of the GPSRM 1's SupMCU utilizing double-precision floating-point calculations, and consumes less than a tenth of the power of the OEM719 when performing the required calculations. Therefore a low-power alternative to keeping the GPSRM 1 powered on continuously is to acquire a valid GPS lock on a periodic basis, and then use the OP while keeping the OEM719 off until the next attempt at a GPS lock.

Figure 6 shows a section of the GPSRM 1's startup code's output to its terminal window. A dedicated Vinto test task has completed a one-day forward orbit propagation given a set of initial conditions.

```
0)00:00:00:00.10 vinti7_splash: Starting...
0)00:00:00:00.30 vinti7_splash: Vinti7 computation completed in 200ms.
0)00:00:00:00.41 vinti7_splash: Vinti7 (MPO) input at t1 = 0.00s: r = [-18982.911692, -25047.137179, -173.044152]km, v = [2.969900, 0.329975, 0.265795]km/s
0)00:00:00:00.53 vinti7_splash: Vinti7 results at t2 = 86400.00s: r = [-11697.635199, 11186.019922, -1879.804836]km, v = [-5.668492, -0.403136, -0.518772]km/s
0)00:00:00:00.63 vinti7_splash: Vinti7 % errors at t2 = 86400.00s: r_err = [0.000000, 0.000000, 0.000000], v_err = [0.000000, 0.000000, 0.000000]
0)00:00:00:00.64 vinti7_splash: Vinti7 check complete -- passed.
```

Figure 6: Sample SupMCU Vinti7 OP calculation at startup

The OP calculations are performed in well under 1s by the GPSRM 1's SupMCU.¹⁷

The GPS receiver + Vinti OP in the GPSRM 1 provides the end-user with tangible on-board benefits. GPS

¹⁵ Note that this OEM719 logging command can also be received via the OEM719's USB and other COM ports.

¹⁶ The 1998 AIAA Vinti book contains vinti6.c, which fails in about one in a thousand test cases due to 2-body convergence problems in kepler1.c. The GPSRM 1's OP uses an updated version of the Vinti code.

¹⁷ Timestamps are shown as dd:hh:mm:ss.tt, where tt (ticks) are hundredths of a second.

data does not contain the "mean Keplerian orbital elements" in the TLE. If SGP4 is used as an on-board OP, the osculating ECI position and velocity vectors from GPS must be converted to mean Keplerian orbital elements and then further reduced to single precision to fit the TLE format. The conversion is normally difficult and success is not guaranteed, and truncation to single precision input format introduces errors in initial position and velocity vectors. Quoting from Vallado [1], "In general, TLE data is accurate to about a kilometer or so at epoch and it quickly degrades [2]." Therefore SGP4 is difficult to be used onboard until the object is cataloged by SSN. Even after an object is cataloged, the TLE of the object may be a few days old resulting in additional initial errors [1, 2] at the time of GPS lock. Vinti propagates from the double precision GPS ECI position and velocity vectors without the unreliable conversion and initial state errors. Even if the SGP4 difficulties of implementation, conversion and initial errors are ignored, the singularities and robustness problems of SGP4 [1, 2, 3, 4] are undesirable for onboard flight software. With GPS state vector as input, Vinti's average magnitude of positional error is typically be at least 2x better than SGP4's for propagation without atmospheric drag. To improve Vinti propagation for objects with drag (perigee altitude less than 200 km), periodic GPS lock can be performed every few orbit revolutions.¹⁸

Power Sources

The GPSRM 1 module uses controllable ideal diodes with programmable current limits to route +3.3V power to the OEM719 module's 3V3 power pin.

The supervisor MCU must be commanded to select `vcc_sys` as the source for the OEM719 module's +3.3V power. Therefore, whenever `+5v_sys` is present on the CubeSat Kit bus connector, even if `+5v_usb` is present in these conditions, the GPSRM 1 module will not draw appreciable power from it.

If/when `+5v_sys` is not present, then the GPSRM 1 may draw its power from +5V via USB, either from a directly connected USB host (via connector J3) or via the CubeSat Kit bus signal `+5v_usb`. The operation of the OEM719 in this configuration depends on the MAXPOWER attribute of the OEM719, which by default is 100mA, but may be configurable to something greater (e.g. 500mA) via firmware updates to the OEM719.

Environmental Design

The GPSRM 1 utilizes the already vibration-resistant OEM719 line of GPS receivers.

The GPS receiver is securely fastened to the GPSRM 1 multi-layer printed circuit board (PCB) via four M3 machine screws that capture it between the PCB, aluminum rails and a machined aluminum cover. The cover is entirely finished with an electrically conductive surface treatment. Two additional M3 screws, the PCB, the cover and the conductive gasket between them function together as an EM shield to minimize radiated emissions from the GPS receiver. The GPSRM 1 implements additional filters and/or ground planes on all signals that pass in and out of the GPS receiver.

The machined aluminum cover also provides additional thermal mass for the GPS receiver. A space-grade thermally conductive gel couples the accessible heat-producing electronics of the GPS receiver to the PCB, which has surface and buried copper planes that function as heat spreaders. These planes are all coupled to the thermal standoff pads at the four corners of the GPSRM 1 PCB.

During GPSRM 1 assembly at Pumpkin, the thermally conductive gel is applied to the GPS receiver in a targeted manner that precludes any trapped air pockets.¹⁹ All remaining air within the volume enclosed by the machined aluminum cover can vent through hole in the PCB where the MCX antenna jack is located.

A light pipe carries the GPS receiver's red/green LED's light to the top surface of the machined aluminum cover, without substantially compromising the GPSRM 1's EM shield. Thus, the OEM719's LED is visible from the sides of the GPSRM 1 even when it is integrated into a larger stack of modules.

¹⁸ This assessment of Vinti vs. SGP4 OPs was provided courtesy of Dr. Gim Der.

¹⁹ The OEM719 module's design has inherent trapped air pockets, inside of the RF sections that are covered in sheet metal RF shields. Potting the entire OEM719 module inside of the machined aluminum cover would lead to a host of problems – including non-venting trapped air pockets.

Use with USB

When powered via the CubeSat Kit bus, the GPSRM 1 provides a means of communicating with the GPS receiver via its USB COM port (J3). A USB cable with a Micro-B connector is required. This feature is provided so that the module can be easily reconfigured by and used with e.g. NovAtel's Connect software.²⁰

I2C Interface

The GPSRM 1 functions as an I2C Slave device.

The GPSRM 1's I2C interface is compatible with 100kHz and 400kHz I2C clock speeds.

When being written to or being read from by an I2C Master device, the GPSRM 1 (as a clock-stretching I2C Slave device) may stretch the I2C clock (`SCL_SYS`) as a means of avoiding overruns. This is part of the I2C protocol.

No pull-up resistors are present on the GPSRM 1. Pull-up resistors must be implemented elsewhere in the system; typically, they are on or close to the system's I2C Master device.

Signal Grounds

In an effort to minimize conducted and radiated emissions, all of the grounds of the GPSRM 1 are tied together into a single net: **DGND**. Those nodes tied to **DGND** include:

1. The grounds for the OEM719 GPS receiver (i.e., pins 10, 13, 16 & 18 of its 20-pin connector P1101).
2. The grounds for the PIC24E Supervisor MCU (both analog and digital).
3. The ground of the USB micro AB connector.
4. **DGND** from the CubeSat Kit Bus Connector **H2**.
5. The (RF) ground of the OEM719 module's MCX GPS antenna connector.
6. The grounds of connectors **J6**, **J7** and **J8**.
7. The heatsink cover / EM shield.
8. The four corner mounting holes of the module, along with their thermal pads.

I/O Level Mapping: GPS Receiver's COM1 I/O level

The OEM719's COM1 port is mapped to the CubeSat Kit bus through low-power level-shifting transceivers. The voltage level on the bus side (`VCCB_ISO`) can be selected via the selective jumpers implemented as zero-Ohm resistors **R8** and **R9**:

²⁰ The Receiver Version window in NovAtel's Connect software can be used to discern the serial number and model number of the OEM719 installed on a given GPSRM 1.

CubeSat Kit GPSRM 1 Rev. D

I/O level Configuration	Description	Example Host	Jumpers	
			Fitted	Omitted
A	COM1 I/O is at 5V logic levels.	PPMs that operate with 5V I/O.	R8	R9
B	COM1 I/O is at 3.3V logic levels.	PPMs that operate with 3.3V I/O (i.e., the majority).	R9	R8

CSK Bus Mapping: GPS Receiver's COM1

For applications that wish to talk serially to the GPS receiver via its COM1 port, four different configurations are supported via the selective jumpers implemented as zero-Ohm resistors R26-R30:

COM1 Configuration	Description	Example Host	Jumpers	
			Fitted	Omitted
A	Maps GPS receiver's TXD1 to IO.5 (URX0) and RXD1 to IO.4 (UTX0).	All PPMs that map UTX0 to IO.4 and URX0 to IO.5.	R26, R29	R27, R28, R30, R31
B	Maps GPS receiver's TXD1 to IO.17 and RXD1 to IO.16.	PPM D1 (PIC24FJ256GA110), configured via PPS to map UART3 to IO.16 (data out) & IO.17 (data in).	R27, R30	R26, R28, R29, R31
C	Maps GPS receiver's TXD1 to IO.33 and RXD1 to IO.32.	With PPM B1 (which has no connections to IO. [33.31]), a user module with e.g. expansion I2C-to-UARTs can connect to IO.32 & IO.33.	R28, R31	R26, R27, R29, R30
D	GPS receiver's COM1 is isolated from CubeSat Kit Bus Connector – interface only through GPSRM 1 Supervisor MCU via I2C.	Any PPM that needs to interface to the GPSRM 1 solely via I2C on SCL_SYS and SDA_SYS.		R26, R27, R28, R29, R30, R31

N.B. For proper operation, a maximum of one pair of jumpers (R26 & R29, R27 & R30, or R28 & R31) should be fitted at any time. Fitting more than one pair of jumpers may damage the GPSRM 1. Jumpers are to be soldered in place by a qualified technician.

CSK Bus Mapping: VARF

VARF can be mapped to IO.31 of the CubeSat Kit Bus. Two different configurations are supported via the selective jumper implemented as zero-Ohm resistor R32:

VARF Configuration	Description	Example Host	Jumpers	
			Fitted	Omitted
A	VARF is not mapped to CSK Bus.	PPMs or other hosts that cannot effectively utilize VARF when mapped to IO.31.		R32
B	VARF is mapped to IO.31.	PPMs or other hosts that have facilities to utilize a programmable clock signal on IO.31.	R32	

CSK Bus Mapping: -RESET

The GPSRM 1 has its own independent reset supervisor (U2). The reset supervisor can be configured to interact with the CubeSat Kit Bus **-RESET** signal as an input to and/or an output. Four different configurations are supported via the selective jumpers implemented as zero-Ohm resistors R3 and R4:

CubeSat Kit GPSRM 1 Rev. D

-RESET Configuration	Description	Resultant Behavior	Jumpers	
			Fitted	Omitted
A	Local reset supervisor U2 is not used, GPSRM 1 is completely disconnected from -RESET.	Supervisor MCU utilizes only its own on-chip BOR/POR circuitry to enforce clean (re-)starts. <i>Not recommended.</i>		R3, R4
B	GPSRM 1's local reset supervisor U2 resets Supervisor MCU and can be triggered via -RESET.	GPSRM 1 can be reset via local reset supervisor U2 and external -RESET signal.	R4	R3
C	Local reset supervisor U2 is not used, GPSRM 1 can drive -RESET signal.	Supervisor MCU utilizes only its own on-chip BOR/POR circuitry to enforce clean (re-)starts. GPSRM 1 can reset the CubeSat Kit Bus by forcing local signal -FORCE_RESET low. <i>Not recommended.</i>	R3	R4
D	GPSRM 1's local reset supervisor U2 resets Supervisor MCU and can be triggered via -RESET. GPSRM 1 can drive -RESET signal.	GPSRM 1 can be reset via local reset supervisor U2 and external -RESET signal. GPSRM 1 can also reset the CubeSat Kit Bus by forcing local signal -FORCE_RESET low – <i>this will in turn force a GPSRM 1 reset. Use with caution.</i>	R3, R4	

Assembly Revisions

As a consequence of the various jumper-driven configurations outlined above, end-users may specify an assembly revision when ordering their GPSRM 1. A binary code is utilized, as shown below, with the resulting assembly revision numbers shown in decimal format, with powers-of-2 weights from left to right:

ASSY REV	R9 or R8	R32	R3	R4	R28 & R31	R27 & R30	R26 & R29	Typical Application
8	R9	-	-	+	-	-	-	Sole interface to Supervisor MCU is via I2C.
9	R9	-	-	+	-	-	+	PPM Ax, OEM719 COM1 on Io.5 & Io.4.
10	R9	-	-	+	-	+	-	PPM Dx, OEM719 COM1 on Io.17 & Io.16.
41	R9	+	-	+	-	-	+	PPM Ax, OEM719 COM1 on Io.5 & Io.4, additional module utilizes VARF on Io.31.
42	R9	+	-	+	-	+	-	PPM Dx, OEM719 COM1 on Io.17 & Io.16, additional module utilizes VARF on Io.31.
44	R9	+	-	+	+	-	-	PPM B1, OEM719 COM1 on Io.33 & Io.32, additional module utilizes VARF on Io.31.
73	R8	-	-	+	-	-	+	Customer PPM with 5V I/O, OEM719 COM1 on Io.5 & Io.4.

References

- [1] Vallado, D.A., Crawford, P., Hujsak, R., "Revisiting Spacetrack Report #3", AIAA, 2006-6753, 2006.
- [2] Hartman, P.G, "Long-term SGP4 Performance", Space Control Operations Technical Note J3SOM-TN-93-01 US Space Command, USSPACECOM/J2SO, Colorado Springs, Colorado, 1993.
- [3] The 1970 Paper in the Journal of Spacecraft by Getchell at NSA, "Orbit Computation with the Vinti Potential and Universal Variables." Contains vinti5.f. Since Vinti does not have singularity for Molniya orbits at or near 63.4 degrees, this SGP4 singularity is eliminated.
- [4] Chapter 5.12 of the 1989 Goddard Trajectory Determination System (GTDS) Mathematical Theory describes the Vinti Theory in terms of accuracy and robustness.

TRADEMARKS

The following are Pumpkin trademarks. All other names are the property of their respective owners.

- Pumpkin™ and the Pumpkin logo
- Salvo™ and the Salvo logo
- MISC™
- CubeSat Kit™ and the CubeSat Kit logo

DISCLAIMER

PUMPKIN RESERVES THE RIGHT TO MAKE ANY CHANGES WITHOUT FURTHER NOTICE TO ANY PRODUCTS HEREIN TO CORRECT ERRORS AND IMPROVE RELIABILITY, FUNCTION, APPEARANCE OR DESIGN. PUMPKIN DOES NOT ASSUME ANY LIABILITY ARISING OUT OF THE APPLICATION OR USE OF ANY PRODUCT OR CIRCUIT DESCRIBED HEREIN; NEITHER DOES IT CONVEY ANY LICENSE UNDER ITS PATENT RIGHTS, NOR THE RIGHTS OF OTHERS.



744 Naples Street
San Francisco, CA 94112 USA
tel: (415) 584-6360
fax: (415) 585-7948

web: <http://www.pumpkininc.com/>
email: info@pumpkininc.com

web: <http://www.cubesatkit.com/>
email: info@cubesatkit.com